

Cooling Tower/Boiler Controllers



W100W Series

The W100W series provide an economical and reliable way to keep your cooling tower, boiler, or condensate water treatment program under control.



Summary of Key Benefits

- Large display with icon based programming makes setup easy
- Universal sensor input provides extraordinary flexibility; the same controller can be used with almost any type of sensor needed
- Multiple language support allows simple setup no matter where your business takes you
- The third control relay allows the controller to be used in more places than other entry level products
- Economical package with no additional cost for timer functionality
- Complete flexibility in the function of each relay
 - Bleed on conductivity
 - Bleed time proportional to makeup water volume
 - Boiler Blowdown on conductivity using intermittent sampling
 - Feed in proportion to bleed time
 - Feed time proportional to makeup water volume
 - Feed as a percentage of elapsed time
 - Biocide timer with pre-bleed and post-feed bleed lockout options
 - Alarm
- Optional analog (4-20 mA) output for recording, datalogging or connection to building energy management systems

W A L C H E M

IWAKI America Inc.

Specifications

Measurement Performance

	Range	Resolution	Accuracy
0.1 Cell Contacting Conductivity	0-3,000 $\mu\text{S/cm}$	0.1 $\mu\text{S/cm}$, 0.0001 mS/cm, 0.01 mS/m, 0.0001 S/m, 0.1 ppm	$\pm 1\%$ of reading
1.0 Cell Contacting Conductivity	0-30,000 $\mu\text{S/cm}$	1 $\mu\text{S/cm}$, 0.001 mS/cm, 0.1 mS/m, 0.0001 S/m, 1 ppm	$\pm 1\%$ of reading
10.0 Cell Contacting Conductivity	0-300,000 $\mu\text{S/cm}$	10 $\mu\text{S/cm}$, 0.01 mS/cm, 1 mS/m, 0.001 S/m, 10 ppm	$\pm 1\%$ of reading
Electrodeless Conductivity	500-12,000 $\mu\text{S/cm}$	1 $\mu\text{S/cm}$, 0.01 mS/cm, 0.1 mS/m, 0.001 S/m, 1 ppm	$\pm 1\%$ of reading
	3,000-40,000 $\mu\text{S/cm}$	1 $\mu\text{S/cm}$, 0.01 mS/cm, 0.1 mS/m, 0.001 S/m, 1 ppm	$\pm 1\%$ of reading
	10,000-150,000 $\mu\text{S/cm}$	10 $\mu\text{S/cm}$, 0.1 mS/cm, 1 mS/m, 0.01 S/m, 10 ppm	$\pm 1\%$ of reading
	50,000-500,000 $\mu\text{S/cm}$	10 $\mu\text{S/cm}$, 0.1 mS/cm, 1 mS/m, 0.01 S/m, 10 ppm	$\pm 1\%$ of reading
	200,000-2,000,000 $\mu\text{S/cm}$	100 $\mu\text{S/cm}$, 0.1 mS/cm, 1 mS/m, 0.1 S/m, 100 ppm	$\pm 1\%$ of reading
Temperature	23 to 500°F (-5 to 260°C)	0.1°F (0.1°C)	$\pm 1\%$ of reading within range

Temperature °C	0	10	15	20	25	30	35	40	50	60	70	80	90	100	110	120	130	140	150	160	170	180
Range Multiplier %	181.3	139.9	124.2	111.1	100.0	90.6	82.5	75.5	64.3	55.6	48.9	43.5	39.2	35.7	32.8	30.4	28.5	26.9	25.5	24.4	23.6	22.9

Note: Conductivity ranges above apply at 25°C. At higher temperatures, the range is reduced per the range multiplier chart.

Inputs

Power

100-240 VAC, 50 or 60 Hz, 7A max

Fuse: 6.3 Amp

Digital Input Signals

State-Type

Electrical: Optically-isolated input.
Provides isolated 9V power.
Current consumption when input is closed: 2.3 mA nominal.

Typical response time: <2 seconds

Devices supported: Any isolated dry contact (i.e. relay, reed switch)

Types: Interlock

Low Speed Counter-Type

Electrical: Optically-isolated input.
Provides isolated 9V power.
Current consumption when input is closed: 2.3 mA nominal.
0-10Hz, 50 msec minimum pulse width

Devices supported: Any device with isolated open drain, open collector, transistor or reed switch

Types: Contacting Flowmeter

High-Speed Counter-Type

Electrical: Optically-isolated input.
Provides isolated 9V power.
Current consumption when input is closed: 2.3 mA nominal.
0-250Hz, 1.25 msec minimum pulse width

Devices supported: Any device with isolated open drain, open collector, transistor or reed switch

Types: Paddlewheel Flowmeter

Outputs

Mechanical Relays (3)

Pre-powered on circuit board switching line voltage, or dry contact, depending upon model code.

If pre-powered, all three relays are fused together as one group, total current for this group must not exceed 6A 6 A (resistive), 1/8 HP (93W)

4 - 20 mA (optional)

Internally powered
Fully isolated
600 Ohm max resistive load
Resolution .0015% of span
Accuracy $\pm 0.5\%$ of reading

Mechanical (Controller)

Enclosure	Polycarbonate
Enclosure Rating	NEMA 4X (IP65)
Display	128 x 64 graphic backlit display
Ambient Temperature	-4 to 131°F (-20 to 55°C)
Shipping Temperature	-4 to 176°F (-20 to 80°C)
Shipping weight	22 lbs (10 kg) (approximately) varies with model

Agency Certifications

Safety: ANSI/UL 61010-1:2012, 3rd Edition
C22.2 No.61010-1:2012, 3rd Edition
IEC 61010-1:2010 3rd Edition
EN 61010-1:2010 3rd Edition

EMC: IEC 61326-1:2005
EN 61326-1:2006

Note: For EN61000-4-6, EN61000-4-3 the controller met performance criteria B.
This equipment is suitable for use in establishments other than domestic and those directly connected to a low voltage (100-240 VAC) power supply network which supplies buildings used for domestic purposes.

Specifications

Dimensions

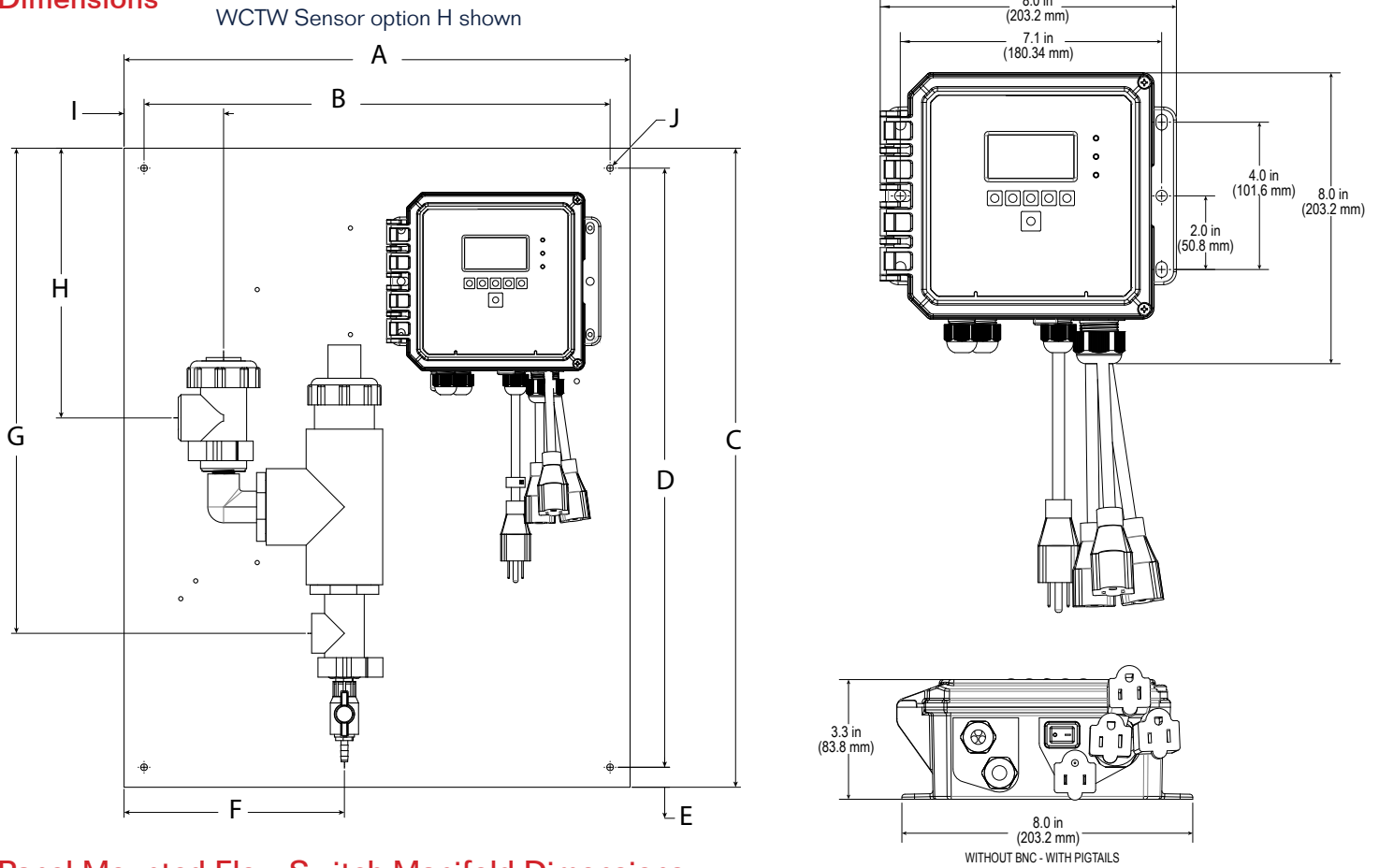

Panel Mounted Flow Switch Manifold Dimensions

	A	B	C	D	E	F	G	H	I	J
WCTW sensor option H	19.0 in 482.6mm	17.5 in 444.5mm	24.0 in 609.6mm	22.5 in 571.5mm	0.80 in 20.3mm	8.3 in 210.8mm	18.2 in 462.3mm	10.1 in 256.5mm	3.7 in 94.0mm	0.25 in 6.35mm
WCTW sensor options B, F	13.0 in 330.2mm	12.0 in 304.8mm	11.8 in 299.7mm	10.8 in 274.3mm	0.5 in 12.7mm	2.0 in 50.8mm	7.2 in 182.9mm	1.9 in 48.3mm	1.6 in 40.6mm	
WCTW sensor option D	22.5 in 571.5mm	21.5 in 546.1mm	11.8 in 299.7mm	10.8 in 274.3mm	0.50 in 12.7mm	8.0 in 203.2mm	6.9 in 175.3mm	3.9 in 99.1mm	4.7 in 119.4mm	

Mechanical (Sensors)

Sensor	Pressure	Temperature	Materials	Process Connections
Graphite contacting conductivity tower	0-150 psi up to 100°F (38°C), 0- 50 psi at 140°F (60°C)	32-140°F (0-60°C)	GFRPP, Graphite, FKM	3/4" NPTF
316 SS contacting conductivity tower	0-150 psi up to 100°F (38°C), 0- 50 psi at 140°F (60°C)	32-140°F (0-60°C)	GFRPP, 316SS, FKM	3/4" NPTF
High pressure tower	0-300 psi (0-20 bar)	32-158°F (0-70°C)	316SS, PEEK	3/4" NPTF
Electrodeless tower	0-150 psi up to 100°F (38°C), 0- 50 psi at 140°F (60°C)	32-140°F (0-60°C)	PP, PVC, FKM	3/4" NPTF
Low pressure manifold	0-150 psi up to 100°F (38°C), 0- 50 psi at 140°F (60°C)	32-140°F (0-60°C)	GFRPP, PVC, FKM, Isoplast	3/4" NPTF
High pressure manifold	0-300 psi (0-20 bar)	32-158°F (0-70°C)	Carbon steel, steel, brass	3/4" NPTF
Boiler/condensate contacting conductivity	0-250 psi (0-17 bar)	32-401°F (0-205°C)	316SS, PEEK	3/4" NPTM

Ordering Information

WCTW
WBLW

Relays/Wiring

Analog Output

- Sensors

Relays/Wiring

- 100H = 3 powered relays, hardwired
- 100P = 3 powered relays, prewired USA power cord & pigtails
- 100D = 3 powered relays, prewired DIN power cord, no pigtails
- 110H = 3 dry relays, hardwired
- 110P = 3 dry relays, prewired USA power cord, no pigtails
- 110D = 3 dry relays, prewired DIN power cord, no pigtails

Analog Output

- N = No analog output
- A = One isolated analog (4-20 ma) output

Sensors (WCTW)

- N = No sensor
- A = Inline/submersion graphite contacting conductivity
- B = Graphite contacting conductivity + Flow Switch manifold on panel
- C = High pressure contacting conductivity
- D = High pressure contacting cond + Flow Switch manifold on panel
- E = Inline/submersion 316SS contacting conductivity
- F = 316SS contacting conductivity + Flow Switch manifold on panel
- G = Inline/submersion electrodeless conductivity
- H = Electrodeless conductivity + Flow Switch manifold on panel

Sensors (WBLW)

- N = No sensor
- A = Boiler sensor with ATC, 250 psi, 20 ft cable
- B = Boiler sensor without ATC, 250 psi, 20 ft cable
- C = Condensate sensor with ATC (cell constant 0.1), 200 psi, 10 ft cable
- D = Boiler sensor with ATC, up to 100 mS/cm (cell constant 10), 250 psi, 20 ft cable



Metering Pumps

The E-Class is the most innovative and comprehensive metering pump product line in the world. Over 50 years of pump experience and a commitment to superior mechanical design has led to development of many industry firsts, including 360 stroke-per-minute technology, IP67 waterproof construction, and the world's highest capacity solenoid metering pumps.



Accessories

To complete your system, Walchem provides high quality accessories that are required for cooling tower, boiler, potable water, and wastewater applications. All of Walchem's accessories are carefully designed and selected for compatibility with our pumps and controllers to enable our customers to provide a complete system solution.



ABOUT US

Walchem integrates its advanced sensing, instrumentation, fluid pumping and communications technologies to deliver reliable and innovative solutions to the global water treatment market. Our in-house engineering is driven by quality, technology and innovation. For more information on the entire Walchem product line, visit: www.walchem.com